

Specifications: Model 319F(60) Flanged Valve

Flanged Horizontal Flow

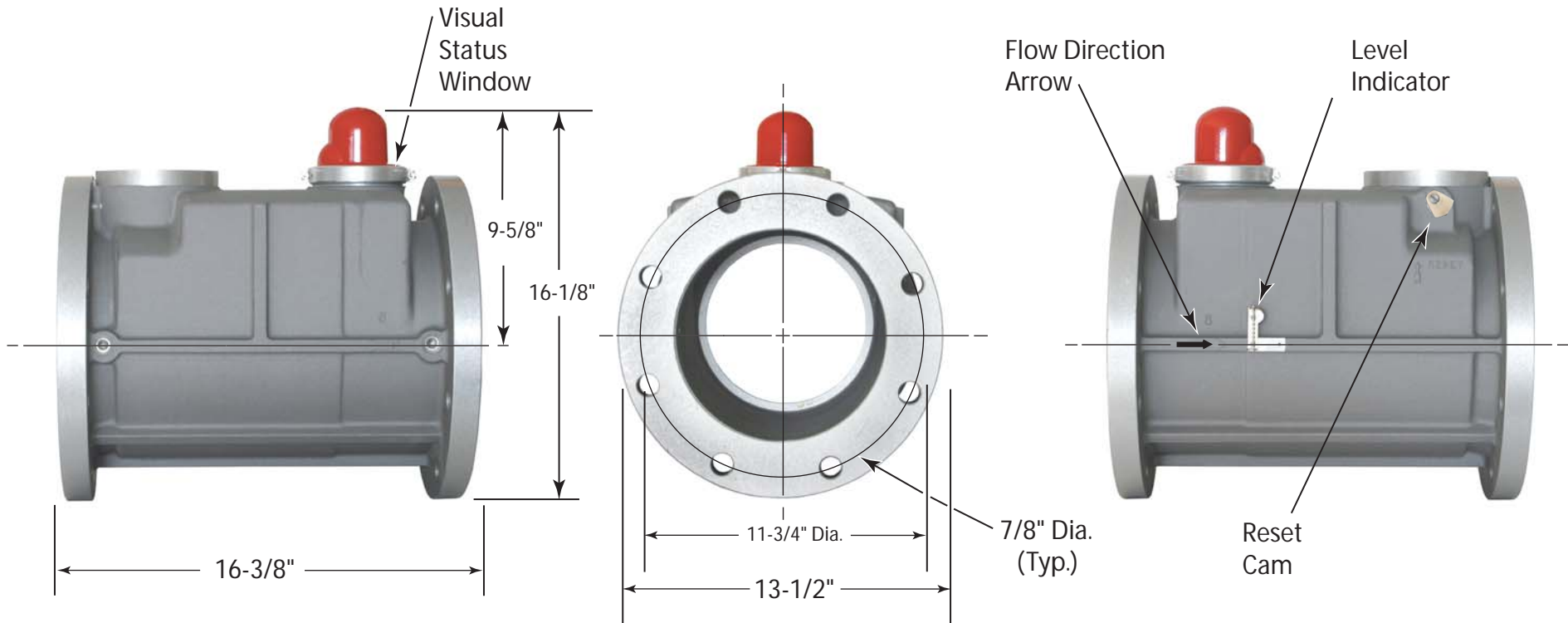

Valve Model#	CA-DSA No.	Length	Height	Diameter	Nominal Pipe Size	APPLICATION	DATA	Diameter On Center	Diameter Hole (Typ.)	Number of Holes
						Max. Pressure	Fuel			
319F	62-02	16-3/8"	9-5/8"	13-1/2"	8"	60 psi	Dry Fuel Gas	11-3/4" Dia.	7/8" Dia.	8

California Seismic Valves are UL listed in the USA and Canada, Certified by the California State Architect's Office, Approved by the City of Los Angeles, and are warranted free of manufacturer's defects for 30 years. All valves meet California Standards for Earthquake Actuated Automatic Gas Shut off Systems, Standard No. 12-23-1, ANSI Z21.70, 1981 and ASCE 25-97 Standards.



Toll Free 866-422-8258
Tel 310-472-7592
Toll Free 866-776-8258
Fax 310-472-5276

